

DETALLE
CANALIZACIÓN

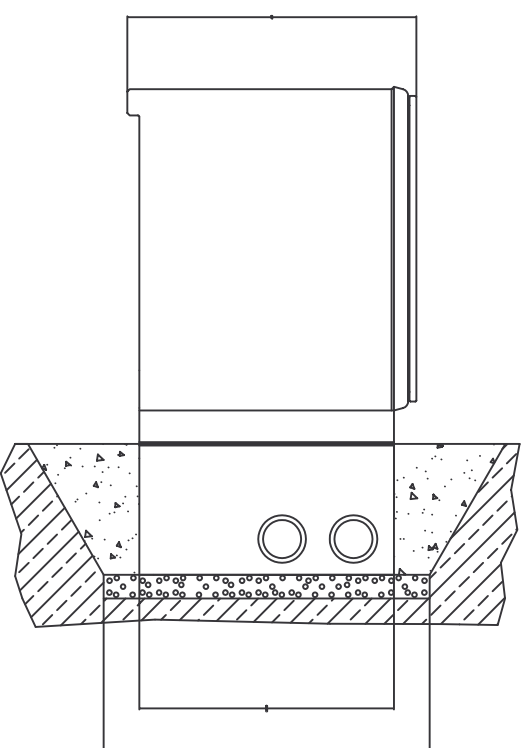

Consultar en caso de
instalación en pendiente

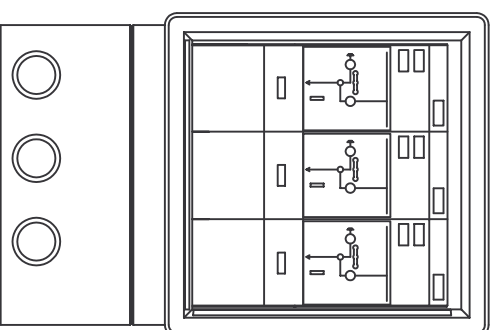
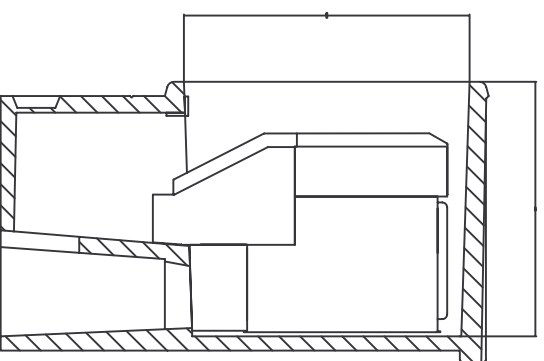
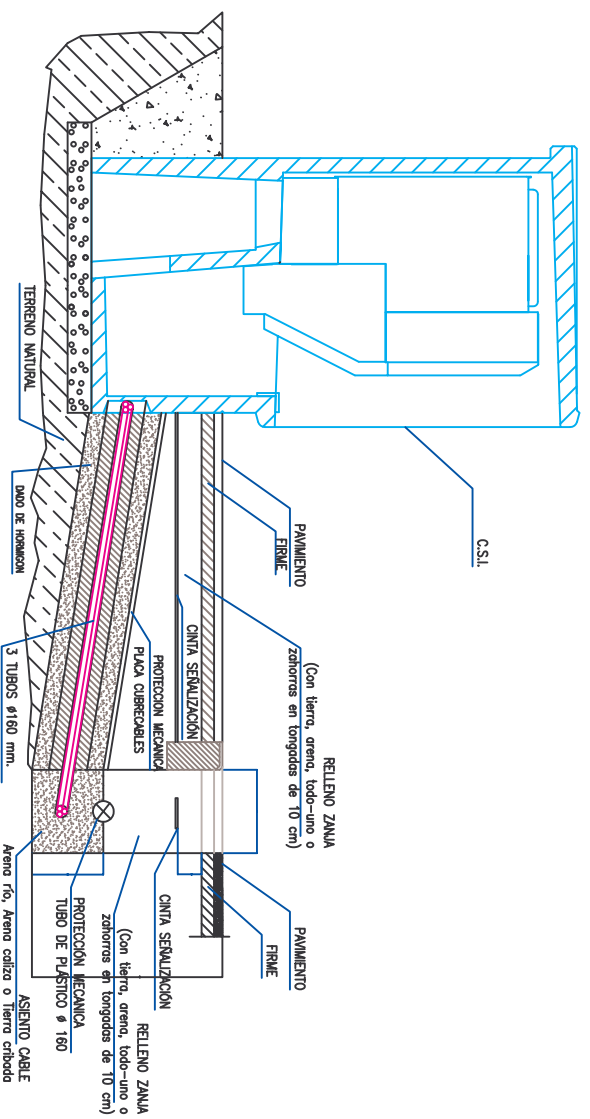
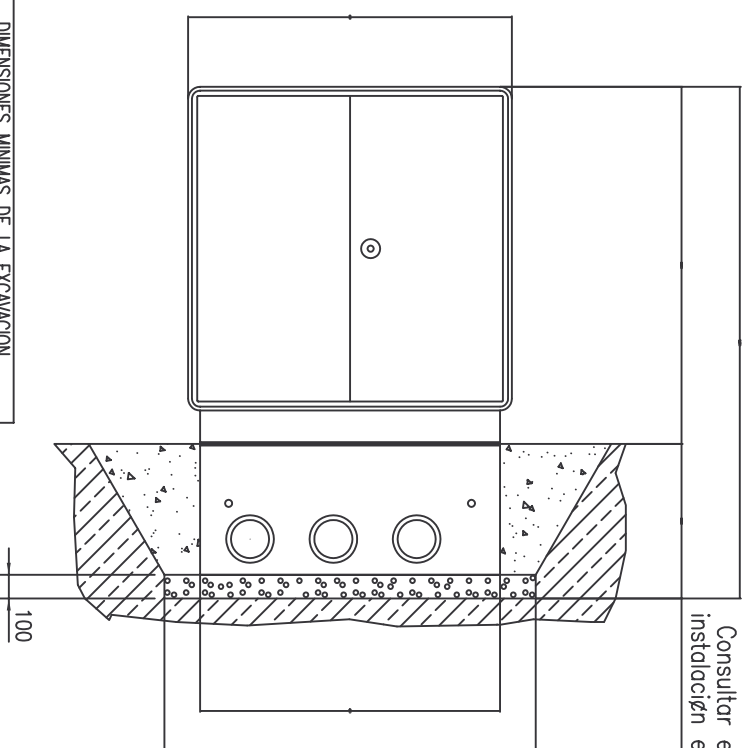

DIMENSIONES MINIMAS DE LA EXCAVACION
1,66 m. ancho x 1,37 m. fondo x 0,65 m. profund.

100

CML CML CML

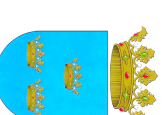
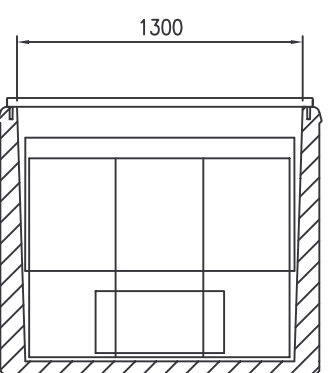
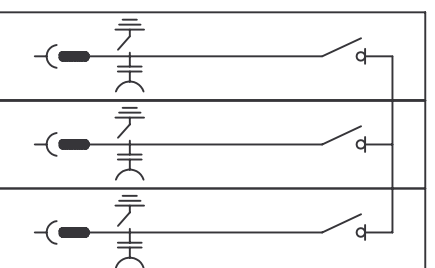

MAGNÍFIC AJUNTAMENT DE BURRIANA

PROYECTO:

PROYECTO DE URBANIZACIÓN DE LA UNIDAD
DE EJECUCIÓN D-1, 2, 4-1 REDELIMITADA

PROMOTOR:

A.I.U. Cami Vell de Valencia



PLANO:
BAJA TENSION
DETALLES

PLANO Nº:

11.4

ESCALA:

S/E

FECHA:

Abril 2011